

Vacuum Technologies
A Unit of ASCO POMPE

LIQUID RING VACUUM PUMP Model AVL 96

PERFORMANCE FEATURES

- Vary port valve design for optimum efficiency across all inlet pressures.
- Near-isothermal compression to safely handle any thermally sensitive and explosive gas.
- Right choice for any wet process.
- EAC TR CU 010/2011 certification.
- EAC TR CU 012/2011 certification.
- Flexibility in motor selection for special and hazardous applications (ATEX).

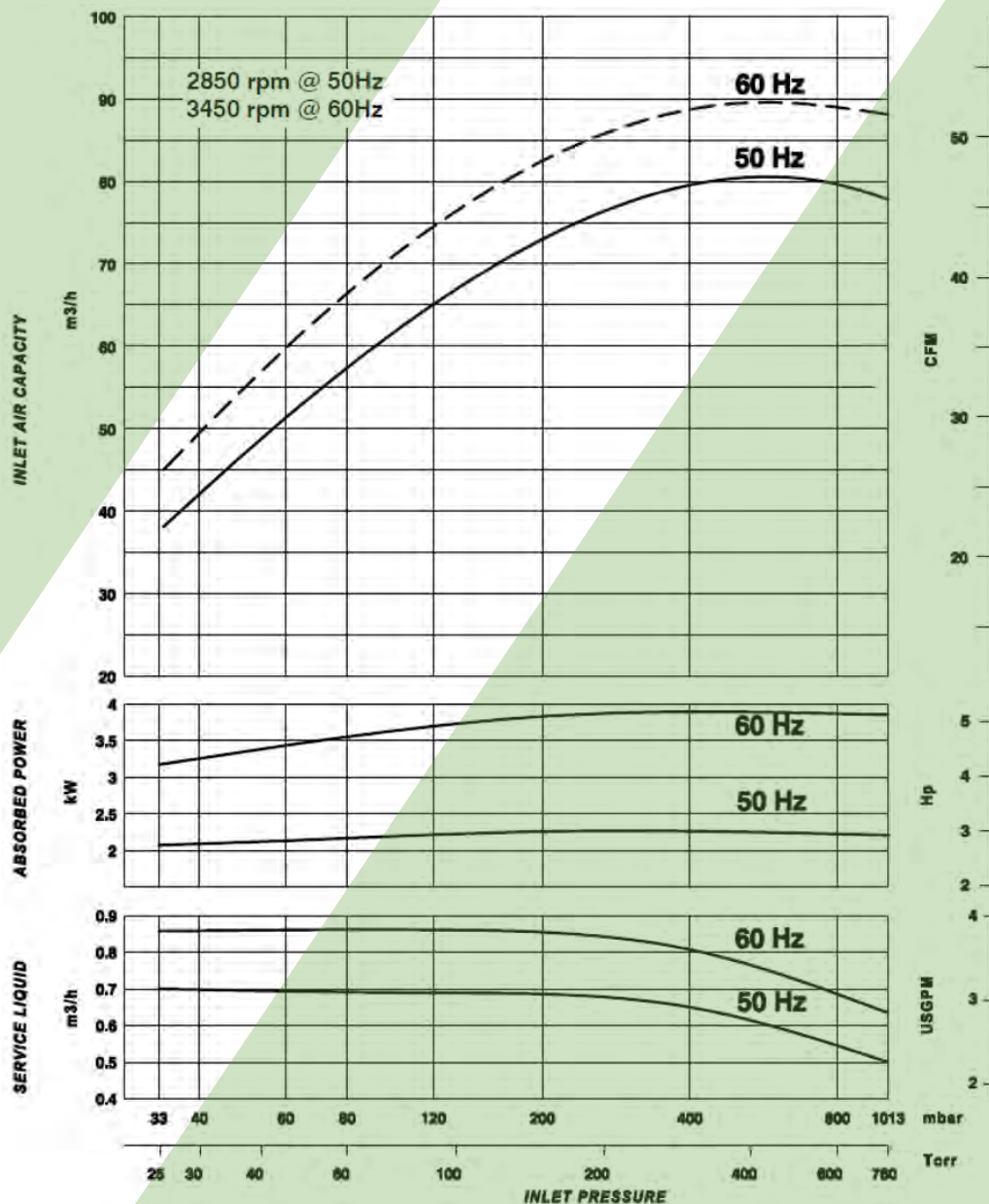

NOTES :

The given data are referred to dry air at the temperature of 20°C, at the atmospheric discharge pressure (1013 mbar), and of supply of service water at 15°C temperature. Performances tolerance $\pm 10\%$.

Product specifications and data are subject to change without notice.

TÜV IT 19 ATEX 049 AR



Performance test in compliance with PNEUROP 6612

LIQUID RING VACUUM PUMP

Model AVL 96



APPLICATIONS

- Vacuum industrial processing
- Sterilization
- Extrusion
- Degassing
- Evaporation and distillation
- Priming
- Vacuum sewage
- Bottling
- Depoultry
- Fish farming

FEATURES

AVL 96 is a simple, versatile and reliable liquid ring pump capable to handle almost any gas mixture including vapors in vacuum or overpressure. The operating principle combined to its accurate design allow for severe duty with high tolerance of liquid carry over. The wide range of suction pressure (down to 33 mbar abs) makes the AVL series suitable for many industrial applications including those ones requesting special or ex ex-proof motors. The stainless-steel port plate and impeller are designed and manufactured with accurate process to reach outstanding and steady performance. The low operating speed associated with the robust and simplified construction grant long service life with minimal maintenance. AVL 96 is available in standard version or full stainless-steel AISI 316 (wetted parts). Other material options, on request.

MATERIALS OF CONSTRUCTION

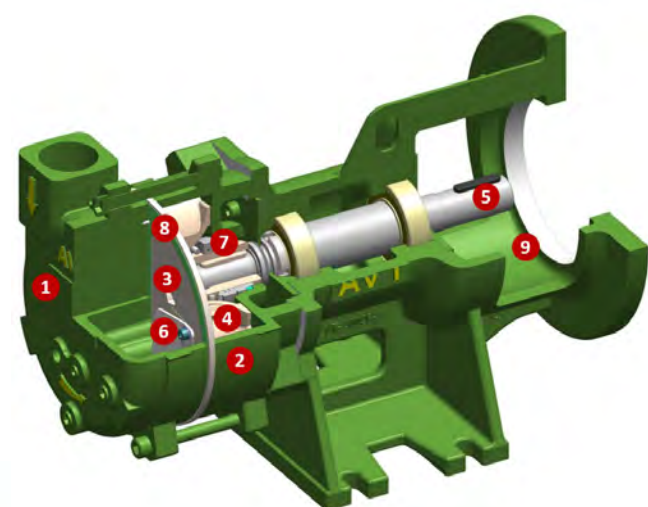

#	PART	CS	SS
1	Suction and discharge casing	CAST IRON (ASTM A278 CL. 250)	SS316 (ASTM A351-CF8M)
2	Housing	CAST IRON (ASTM A278 CL. 250)	SS316 (ASTM A351-CF8M)
3	Port plate	SS 316 (ASTM A240)	SS 316 (ASTM A240)
4	Impeller	SS316 (ASTM A351-CF8M)	SS316 (ASTM A351-CF8M)
5	Shaft	AISI 420 (ASTM A276 TY420)	AISI 420 (ASTM A276 TY420)
6	Vary port valve	PTFE	PTFE
7	Mechanical seal	CARBON/SIC/ VITON/SS316	CARBON/SIC/ FEP/SS316
8	Gasket	ARAMIDIC FIBER	ARAMIDIC FIBER
9	Lantern	CAST IRON (ASTM A278 CL. 250)	CAST IRON (ASTM A278 CL. 250)



Model AVL 96

LIQUID RING VACUUM PUMP

2D DRAWING

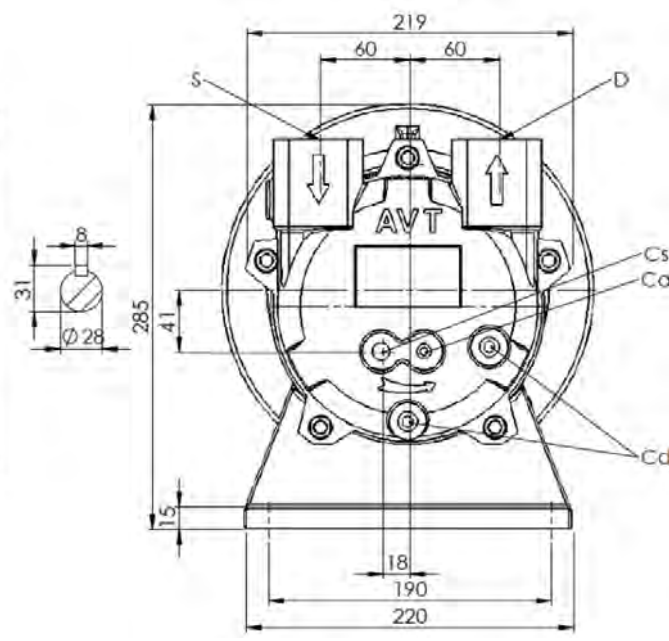
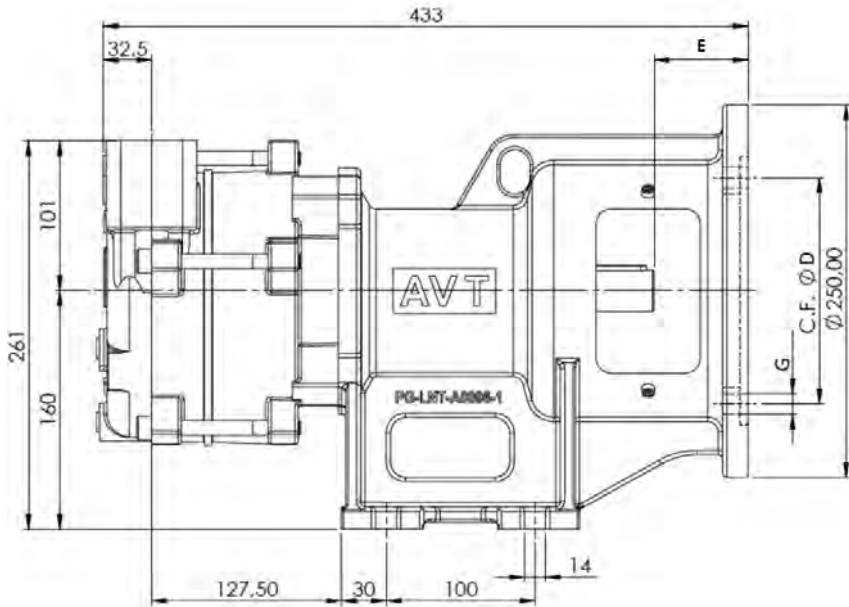

CONNECTIONS

S	G 1"1/2	Suction
D	G 1"1/2	Discharge
Cs	G 1/4"	Service liquid
Cd	G 1/4"	Pump drain
Ca	G 1/8"	Anti-cavitation

Dimensions [mm]

PUMP	kW	Hz	Weight [Kg]	D	G	E
AVL 96-50	2,2	50	38	Ø 165	M10	53
AVL 96-60	4	60	38	Ø 215	Ø 14	63

TECHNICAL SPECIFICATIONS

	AVL 96-50	AVL 96-60
Nominal capacity	81 m ³ /h	90 m ³ /h
Ultimate pressure	33 mbara	33 mbara
Dry weight	38 kg	38 kg
Max gas temperature	120°C	120°C
Max liquid temperature	50°C	50°C
Casing design pressure	3 barg	3 barg

	AVL 96-50	AVL 96-60
Noise level	72 dBA	72 dBA
Motor power *	2,2 kW	4 kW
Motor speed *	2850 rpm	3450 rpm
Motor frame size *	90	100
Motor mounting *	B5	B5
Volt./Ph/Frequency *	230-400V/ 3/50Hz	277-480V/ 3/60Hz

*electric motor not included

SPARE PARTS AVAILABLE

LIQUID RING VACUUM PUMP Model AVL 96

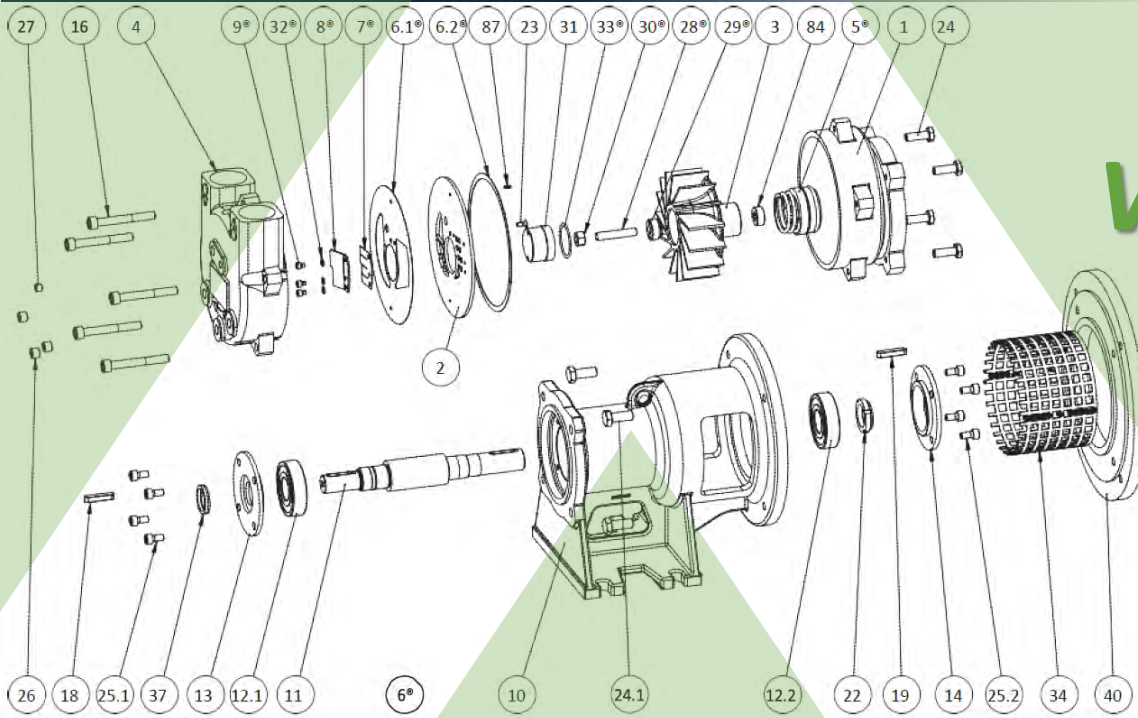

Pos.	Description	Q.ty
1	Casing	1
2	Port plate	1
3	Impeller	1
4	Suction/discharge casing	1
5 [®]	Mechanical seal	1
6.1 [®]	Suction/discharge casing-port plate gasket	1
6.2 [®]	Casing port plate gasket	1
7 [®]	Vari-port valve	1
8 [®]	Valve plate	1
9 [®]	Screw	3
10	Bearing housing	1
11	Shaft	1
12.1	Bearing drive end	1
12.2	Bearing non drive end	1

Pos.	Description	Q.ty
13	Bearing cover drive end	1
14	Bearing cover non drive end	1
16	Screw	5
18	Impeller key	1
19	Coupling key	1
22	Bearing nut	1
23	Screw	1
24	Screw	4
24.1 [®]	Screw	4
25.1	Screw	2
25.2	Screw	2
26	Plug	3
27	Plug	1

Pos.	Description	Q.ty
28 [®]	Stud	1
29 [®]	Adjusting nut	1
30 [®]	Nut	1
31 [®]	Impeller nut	1
32 [®]	Washer	3
33 [®]	O-Ring	1
34	Coupling guard	1
37 [®]	V-Ring	1
84 ^{**}	Spacer	1
87	Locating pin	1

** Only for AVL 96 50Hz
[®] Repair kit part

OPERATION MODES

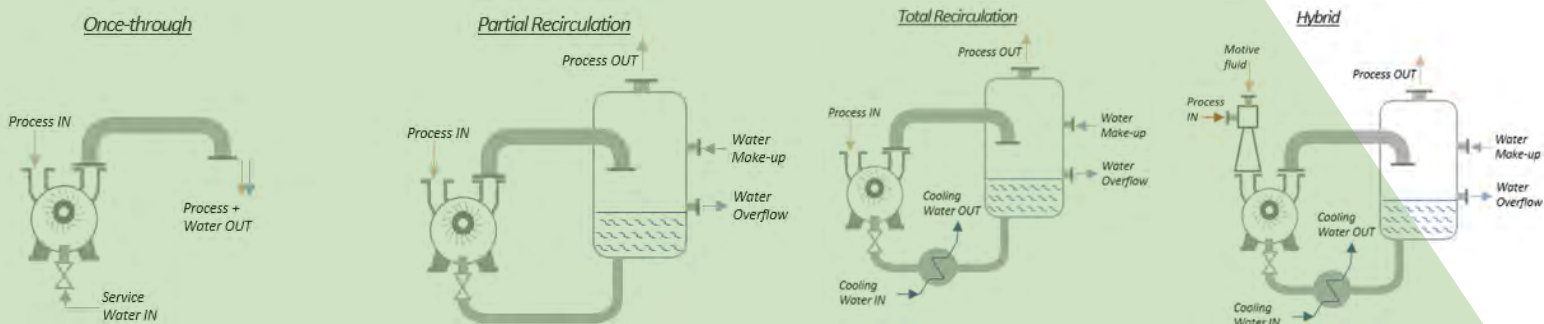

Rev.1 – 04.2021



Asco Vacuum Technologies

Asco Pompe S.r.l.
 Via Silvio Pellico, 6/8
 20089 Rozzano (MI) – Italy
 Phone: +39 02 892571
 Fax: +39 02 89257201
 Mail: info@ascovacuum.com
www.ascovacuum.com